

GAS LEAKAGE DETECTOR

GAS SHUT-OFF DEVICE WITH GAS LEAKAGE DETECTOR(32A, 40A, 50A)

■ AUTO SHUT-OFF VALVE ■ MODEL : SHT-832-3(3Channel)

FEATURES

- ⊙ Functions of long-range opening/closing and automatic shut-off during gas leakage.
- ⊙ The controller confirms the status of opening/closing. ⊙ The quick shut-off function prevents accidents in advance.
- ⊙ The monitoring unit can be additionally extended from basic 3, 6lines(Optional).
- ⊙ Built-in remote monitoring function with opening/closing relay output(Optional).
- ⊙ Minimize the exterior size and consumption electric power(built-in SMPS).
- ⊙ SHT-832-3(3Channel) can be applied to automatic control motor valve systems in every plant, and heating and cooling facilities.



SHT-832-3



SHT-832-6



SHT-ASV(P)

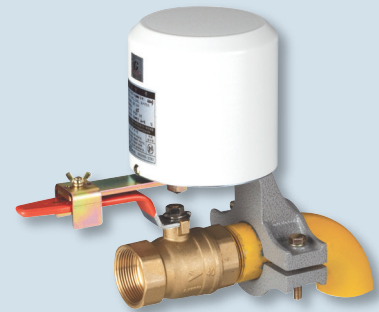

SPECIFICATION

CONTROLLER

- | **Model No.** | SHT-832-3(3Channel), SHT-832-6(6Channel), Wall-mounted type
- | **Model No.** | SHT-ASV(P) (SHT-970 panel insertion type)
- | **Type** | Gas leakage shut-off device with gas leakage detector
- | **Operating power** | 110~220V.AC, 50/60Hz
- | **Consumption electric power** | During normal operation(4.8W)/During an alarm(11W)
- | **Control Type** | Current control type
- | **Receive Type** | Voltage memory type
- | **Alarm Input** | 3Channel, 6Channel
- | **Alarm Type** | Buzzer alarm type(Volume: about 70dB)
- | **Output Signal** | 24V.DC(Shut-off operating voltage)
- | **Output Signal** | OPEN/CLOSE/ALARM(Relay contact) - (Option)
Alarm input line extension port
- | **Operating Display** |
(LED) Opened: Green, Close: Yellow, Alarm: Red, Fuse check: Red
(FND) Opened: OP, Close: CL,
While opening: OP Flickering, While Closing: CL Flickering
- | **Open/Close Type** | Automatically closed during manually open/close or alarm input
- | **Operating Temp /Humi** | -40°C~+70°C/ Less than 95%
- | **Power Input Cable** | 110~220V.AC - 2wire
- | **Detector Input Cable** | 2wire - AC type single detector or detachable detector
3wire - DC type single detector
- | **Shut-off Device Output** | 2wire(Red+, Black-)
- | **Weight** | 1.3Kgs

SPECIFICATION

SHUT-OFF DEVICE

- | **Model No.** | SHT-832A, 840A, 850A
- | **Operating power** | 24V.DC
- | **Gas pipe size** | 32A, 40A, 50A
- | **Shut-off Time** | Less than 20sec
- | **Open/Close Angle** | 90°(Limit switch type)
- | **Body material** | STEEL 1.0t
- | **Gear material** | S45C for the gear
- | **Use Valve** | Ball valve
- | **Operating Type** | Handle operation method
- | **Installation Type** | Cable bolt tightening type
- | **Operating Temp /Humi** | -40°C~+70°C/ Less than 95%
- | **Cable** | CVW or VCTF 1.5sq × 2wire/Max 100M
- | **Weight** | 3.2Kgs

DIMENSION (mm)

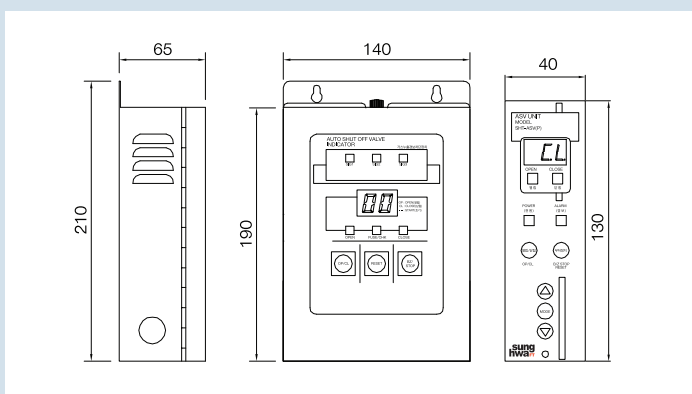

DIMENSION (mm)

